

Leybold

SOGEVAC[®]

SV25 B

Single-stage, oil-sealed rotary vane pump

**Original Operating Instructions GAET02314_002_C2
and list of Spare Parts**

Ref :
960250 to 960266
and their variants

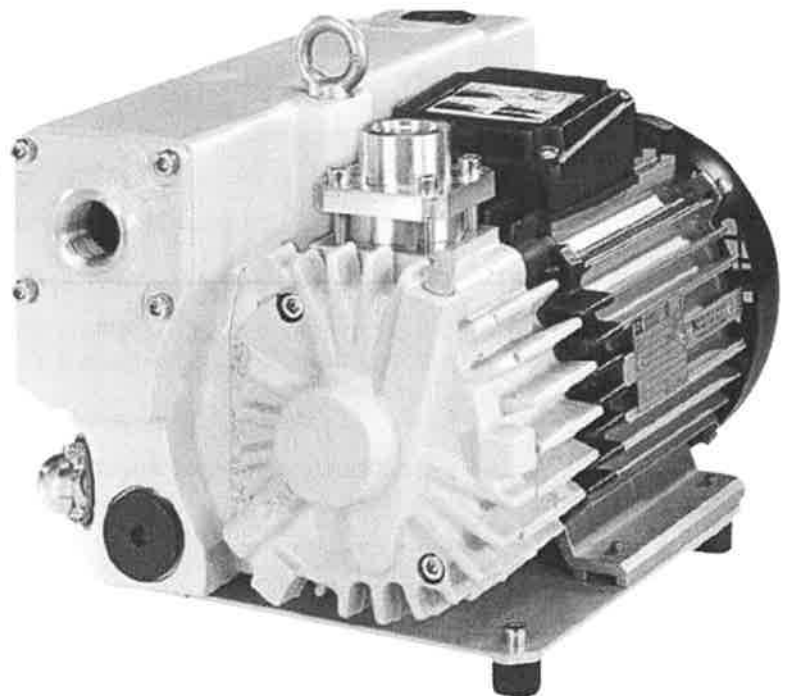

Safety Information

Important Safety Information

Warning



It is mandatory that these operating instructions be read and understood prior to the vacuum pump installation and start-up.

Notes

Under certain operating conditions, dangerous situations may occur when running the vacuum pump. If this happens, please contact our local office.

The SOGEVAC® vacuum pumps have been manufactured according to the latest technical standards and safety regulations. If not installed properly or not used as directed, dangerous situations or damage might occur.

Warning

Indicates procedures that must be strictly observed to prevent hazards to persons.

Caution

Indicates procedures that must be strictly observed to prevent damage to, or destruction of the appliance.

Figures

The references to figures, e. g. (2/10) consist of the Fig. No. and the item No. in that order.

We reserve the right to alter the design or any data given in these Operating Instructions. The illustrations are not binding.

Warning



When working on the pump system always observe the Operating Instructions.

Disconnect the unit from the power supply before starting any work and wait 2 minutes

Take appropriate precautions to insure that the pump cannot unwillingly start.

If the pump has pumped hazardous gases it will be absolutely necessary to determine the nature of the hazard involved and take the appropriate safety precautions.

Observe all safety regulations !

Take adequate safety precautions prior to opening the intake or exhaust port.

Safety Information

Leybold-Service

If you send a pump to Leybold indicate whether the pump is free of substances damaging to health or whether it is contaminated. If it is contaminated also indicate the nature of hazard.

For this you must use the form we have prepared and which will be provided upon request.

A copy of this form, "Declaration of Contamination of Vacuum Instruments and Components" is reproduced at the end of the Operating Instructions.

Please attach this form to the pump, or enclose it with it. This Declaration is required to meet the law and to protect our personnel.

Leybold will return any pump received without a "Declaration of Contamination" to the sender's address.

The pump must be packaged in such a way that it will not be damaged during shipping, and so that no harmful substances can escape from the package.

Warning



Contents

Operating instruction	5
1 Description	5
1.1 Principle of operation	6
1.2 Standard specification	6
1.3 Technical characteristics	7
1.4 Connection fittings	10
1.5 Lubricants	12
1.6 Transport and Packing	12
1.6.1 Transport	12
1.6.2 Packing	13
2 Installation	14
2.1 Installation	14
2.2 Connection to system	15
2.3 Connection to exhaust side	15
2.4 Oil filling	15
2.5 Electrical connections	16
2.6 Operating advices	16
2.7 Shutdown	16
3 Maintenance	17
3.1 Maintenance schedule	18
3.2 Oil level	18
3.3 Oil changing	19
3.4 Exhaust filter replacement	19
3.5 Gas ballast valve cleaning	19
3.6 Inlet flange sifter cleaning	19
3.7 Anti-suck back valve cleaning	19
3.8 Fan cover cleaning	19
3.9 Checking the oil recovery system	19
Problem analysis	20
EU Declaration of Conformity	21
Declaration of Contamination	22
Spare parts List	23

Warning



This Manual is valid for standard products. If the delivered pump is a special version, then the pump will be delivered with an additive document which is to be understood as a part of the Instruction Manual.

Description

1 Description

SOGEVAC® pumps are designed for pumping of inert gases in the range of medium vacuum, between atmospheric pressure and ultimate pressure of the pump.

When removing condensable vapours, a gas ballast valve must be provided.

SOGEVAC® pumps are not designed for pumping of aggressive, corrosive, flammable or explosive gases.

By presence of aggressive, corrosive, flammable or explosive gases, contact Leybold.

These pumps are not designed for working in flammable or explosive environment.

In case of doubt, contact Leybold.

The pumps are not suitable for pumping liquids or media which contain dust. Corresponding protective measures must be taken.

In case of doubt, contact Leybold.

Before Pumping greater than atmospheric concentrations of oxygen (> 20 %) or other highly reactive gases, the pump must be modified, degreased and a special oil (such as PFPE) must be used.
This is not possible on this pump.

Warning



Caution

Take adequate safety precautions.

Contact Leybold for important safety instructions.

Description

1.1 Principle of operation

The SOGEVAC® pumps are single-stage oil-sealed rotary vane vacuum pumps.

The rotor, having three slots in which the vanes are sliding, is eccentrically installed in a pump cylinder (stator). The vanes separate the interior space into 3 chambers. The volume of these chambers varies with the rotation of the rotor.

The gas sucked into the inlet chamber is compressed and then pushed out at the exhaust valve.

The oil injected in the inlet chamber guarantees the air-tightness, the lubrication and cooling of the pump. It is dragged off by the compressed gases and roughly separated by gravity when entering in the oil sump. A fine separation is then operated in the exhaust filter, which retains > 99,9 % of the oil aerosols. An internal transfer pushes the collected oil back into the vacuum generator, the transfer is operated by a float valve to avoid atmospheric air coming from the oil casing to the inlet of the pump when no oil is present in the recovery system. The oil circulation functions by differential pressures.

Depending on catalog numbers, the pumps are equipped with a permanent gas ballast for pumping condensable vapours.

The anti suck back valve at the inlet flange avoids oil coming back into the inlet line when the pump is stopped.

The anti suck back valve is not a safety valve, and works safety only below 100 mbar and in good and clean condition.

1.2 Standard specification

The pumps with three-phase motors are supplied with cable glands on the motor.

The amount of oil needed for the first filling is supplied next to the pump.

The intake port is blanked off by a protective cap.

Stability of pump is insured with accessories of Leybold.

Mounting of any other accessory will engage the responsibility of user concerning stability of pump.

When ordering spare parts, please always state the serial and catalog numbers of the pump.

Description

1.3 Technical characteristics

Technical data		50Hz	60Hz
Nominal pumping speed ¹⁾	m ³ /h	26	31
Pumping speed ¹⁾	m ³ /h	22.5	25
Ultimate partial pressure without gas ballast ¹⁾	mbar	≤1.0	≤1.0
Ultimate total pressure with small gas ballast ¹⁾	mbar	≤1.5	≤1.5
Water vapour tolerance ¹⁾	mbar	10	10
Water vapour tolerable load ¹⁾³⁾	g/h	85	100
Noise level ²⁾	dB (A)	64	67
Motor power - Rated rotational speed	kW- min ⁻¹	0.9-3000	1.1-3600
Protection - Isolation		IP55 - F	IP55 - F
Leak rate	mbar.l.s ⁻¹	1X10 ⁻³	1X10 ⁻³
Oil type / capacity	L	LVO 120 / 0.5	LVO 120 / 0.5
Weight with mineral oil		29(3φ)-27(1φ)	29(3φ)-27(1φ)
Intake connection		G 3/4 + G1/2	G 3/4 + G1/2
Exhaust connection		G 3/4	G 3/4

1) to DIN 28400 and following numbers

2) operated at the ultimate pressure without gas-ballast, free-field measurement at a distance of 1 m

3) with room temperature 20 to 25 °C

The use of other oils or parts may change the technical data.

Ordering Information

SV B 25 m3/h				
P/N	PUMP	MOTOR	G/B	INLET & EXHAUST CONNECTIONS
960250	SV25 B	A	N	G 3/4+Adapt.1/2
960251	SV25 B	A	Y	G 3/4+Adapt.1/2
960252	SV25 B	A	N	NPT 3/4+Adapt.1/2
960253	SV25 B	A	Y	NPT 3/4+Adapt.1/2
960255	SV25 B	B	N	G 3/4+Adapt.1/2
960256	SV25 B	B	Y	G 3/4+Adapt.1/2
960257	SV25 B	B	Y	NPT 3/4+Adapt.1/2
960261	SV25 B	C	Y	NPT 3/4+Adapt.1/2
960266	SV25 B	D	Y	G 3/4+Adapt.1/2

MOTOR:

A=3~230/400V, 50Hz IE3

265/460, 60Hz IE3

200-240V / 346-415V±10%,50Hz

200-277V / 346-480V±10%,60Hz

B=230V±10%,50Hz&60Hz

C=US single phase110-120V±10%,60Hz

GB Y=0.4 Nm3/h

Description

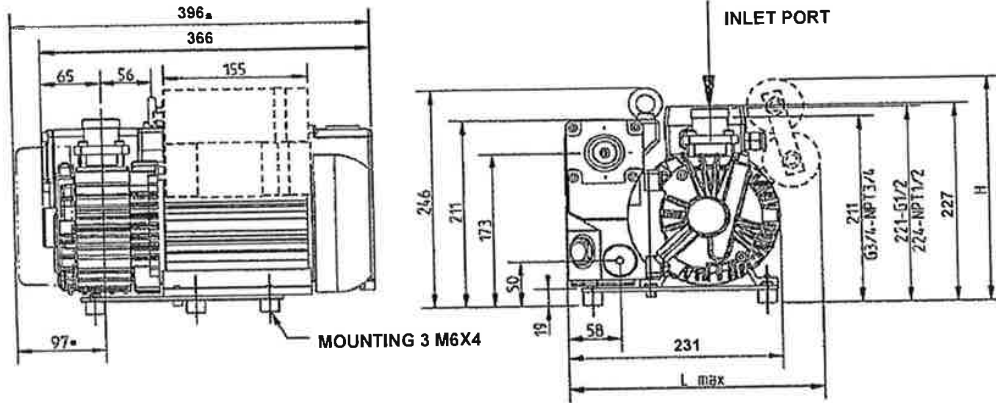

SPACE FOR EXHAUST FILTER EXCHANGE AND COOLING

SPACE FOR THE MOTOR'S VENTILATION

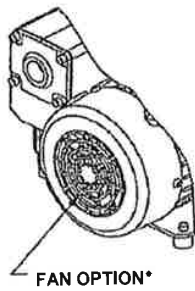
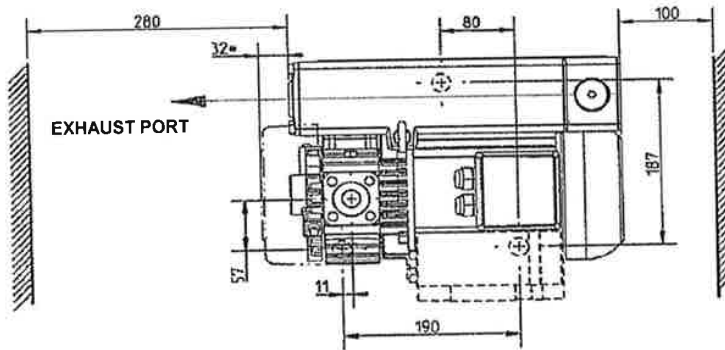

Kaf. -Nr Ref. No Ref.	SV25 B typ/type	Kondensatoren Capacitors Condensateurs	L max	H	Gewicht Weight Poids
960255-960256-960257	1~ 230V	C1	275	193	26kg
960261	1~ 115V	C1 + C2	275	235	27kg
960266	1~ 100V	C1 + C2	275	253	27kg
960250-960251-960252-960253	3~	0	231		29Kg

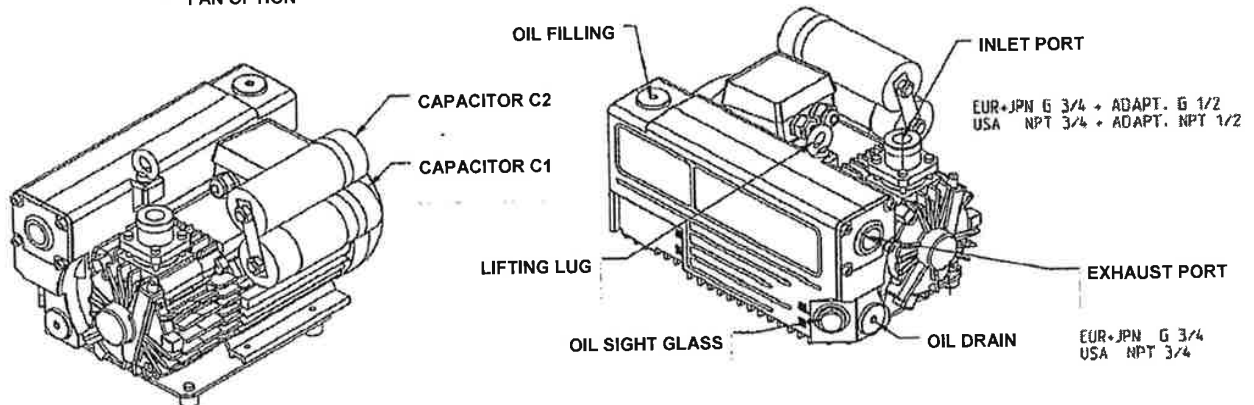

Description

Pumping speeds

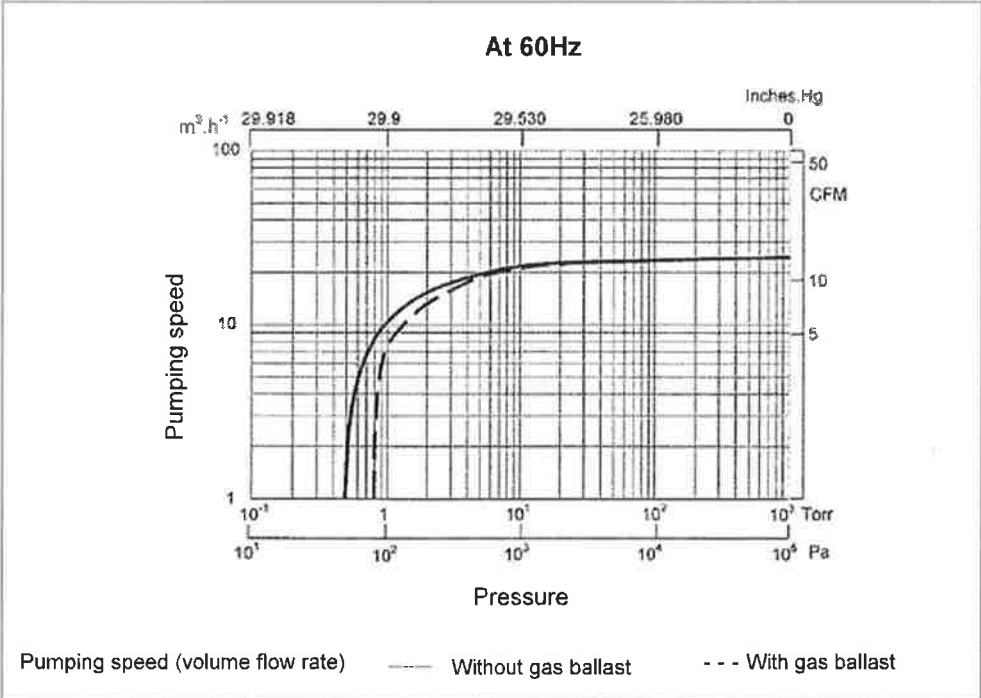
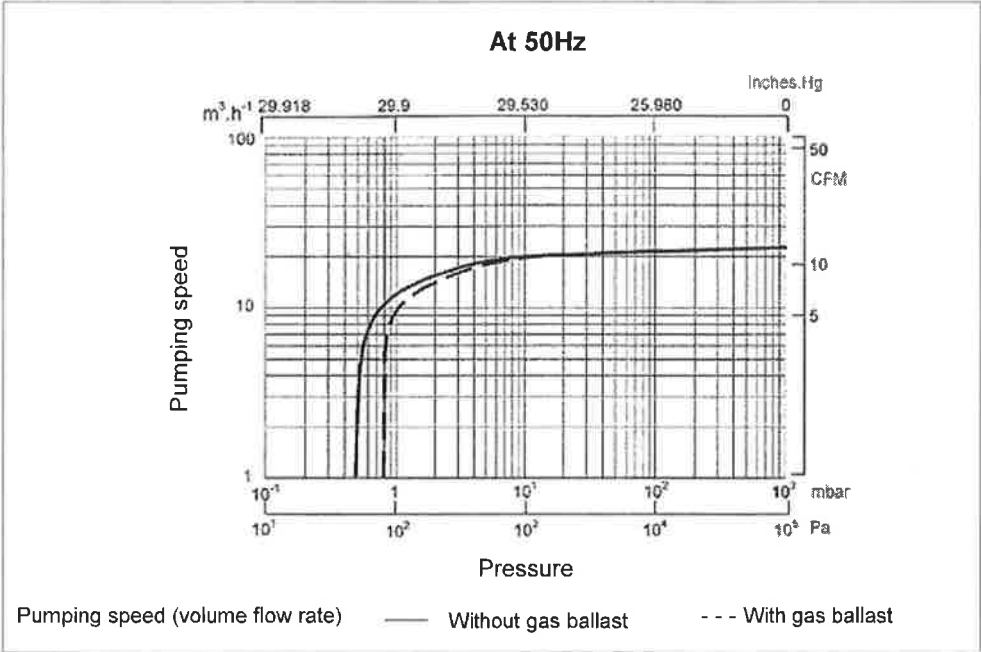

Description

1.4 Connection fittings

Item	Specification	Size	Cat. No.
1*	Reduction + O-ring	G 3/4 M - G 1/2 F	951 24
2	Connecting piece (three piece)	G 1/2 M/F	711 18 020
3	Screw in nipple	G 1/2 M - 16KF	711 18 120
4	Centering ring	DN 16KF	183 26
5	Clamping ring	DN 16KF	183 41
6	Hose connection	DN 16KF- 25mm	711 18 300
7	Hose connection	G 1/2 M - 25mm	711 18 011
8	PVC tubing	25mm	711 18 323
9	T - piece	G 1/2 M-F-F	711 18 250
10	Vacuum control valve	G 1/2 M	951 86
11	Vacuum control valve with shut-off valve	G 1/2 M	951 87
12	Ball valve	G 1/2 M/F	711 30 113
13	Spring vacuum meter	G 1/2 M	951 92
14	Elbow 90°	G 1/2 M/F	711 18 210
15	Dust filter paper	G 1/2 M/F	951 50
15	Dust filter charcoal	G 1/2 M/F	711 27 092
15	Dust filter metal	G 1/2 M/F	711 27 093
15	Dust filter polyester	G 1/2 M/F	711 27 094
	Inlet filter element for filter pos. (15):		
	Filter element paper		710 40 760
	Filter element charcoal		E710 65 713
	Filter element metal		E710 65 813
	Filter element polyester		712 61 280

*Delivered with the pump depending on pump cat no.

Description

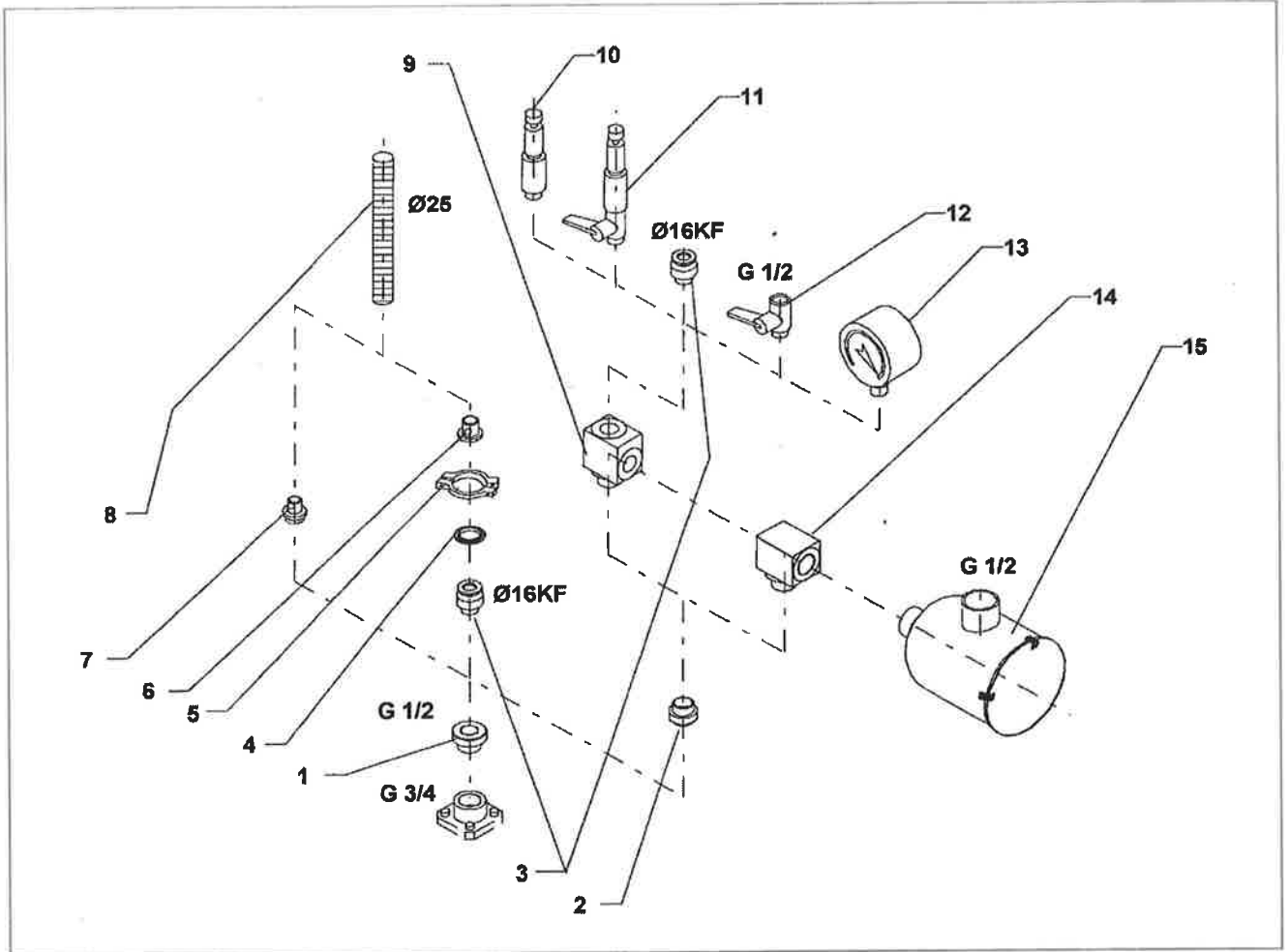

Description

1.5 Lubricants

The SOGEVAC® SV25 B should be run with LV0120, or an equivalent oil approved by Leybold that meets these requirements:

- low vapor pressure, when at high temperatures;
- flat viscosity curve;
- minimum water content and absorption;
- good lubricating properties; and
- resistant to aging under mechanical strain.

When using other oil brands, employ low doped, non detergent mineral oils of viscosity class ISO VG 32.

Using the other special-grade lubricants for specific applications is possible.

Please consult Leybold.

Only use lubricants which have been fully qualified by Leybold.

Oil LVO120	Ref.No.
1L	L12001
5L	L12005
20L	L12020

1.6 Transport and Packing

1.6.1 Transport

SOGEVAC® vacuum pumps pass a rigorous operating test in our factory and are packed to avoid transport damage. Please check packing on delivery for transport damage.

Packing materials should be disposed off according to environmental laws or re-used.

These operating instructions are part of the consignment.

The connection ports are blanked off by plastic protective caps or self-adhesives. Take these caps or self-adhesives away before turning on the pump.

The necessary LV0120 oil is shipped in a separate can.

Pumps which have been filled with oil must only be moved in the upright position (horizon-tally). Otherwise oil may escape. The angle of slope may not be over 10° max. Avoid any other orientations while moving the pump.

Use only lifting devices appropriated to the pump weight. Check name plate. Do not use other pump elements than the lifting lugs as handles.

Description

1.6.2 Packing

Check the pump for the presence of any oil leaks, because there is the danger that someone may slip on the oil which has leaked from the pump.

Warning



Until the pump is put back in to service once more, the pump should be stored in a dry place, preferably at room temperature (20 °C). Before taking the pump out of service, it should be properly disconnected from the vacuum system, purged with dry nitrogen and the oil should be exchange too. The inlet and exhaust ports of the pump must be blanked off using the shipping seals which are included upon delivery of the pump. The gas ballast must be closed and if the pump is to be shelved for a longer period of time it should be sealed in a plastic bag together with a desiccant (Silica gel).

Caution

If the pump has been shelved for over one year, standard maintenance must be run and the oil must be exchanged too before the pump is put in to service once more. We recommend that you contact the service from Leybold.

Installation

Warning



2 Installation

The standard pump is not suitable for installation in explosion hazard areas. Please contact us, when you are planning such an application. Before installing the pump you must reliably disconnect it from the electrical power supply and prevent the pump from running up inadvertently. The pump must only be installed by suitably qualified and trained personnel.

Observe all safety regulations.

In door use only.

2.1 Installation

It is essential to observe the following instructions step by step to ensure a safe start-up.

Start-up may only be conducted by trained specialists.

The pump can be set up on any flat, horizontal surface on its rubber supports. Under the pump are threaded bores M6 for securing the pump or screwing in vibration absorbers (extras).

Caution

The oil level cannot be read properly if the pump is tilted. This may lead to insufficient being sucked in even though the oil level glass is still covered. The pump's ambient temperature should be between 12°C (55°F) and 40°C (104°F). By modifying the pump or changing the oil type, the pump can be run at a higher or lower ambient temperature. Please consult us about this.

To ensure adequate cooling of the pump; leave space at the air intake and exhaust points (see Fig. 1). Also ensure that there is enough space for changing the exhaust filter (see Fig. 1).

Make sure to keep the air intake of the motor clean.

The pump must be kept clean (no dust deposit). Rel. humidity \leq %95 w/o condensation.

2.2 Connection to system

The inlet flange can be connected with a vacuum-tight flexible hose and/or pipe.

The pipes should cause no stresses on the pump's flanges. If necessary, compensators must be installed.

Restriction of the pipes must be avoided in order not to decrease the pumping speed of the pump. The nominal diameter of the pipes has to be least the same as the diameter of pump's inlet flange.

When pumping condensable vapours, a gas ballast valve must be installed.

Liquid and solid particles must not enter the pump. Install the adequate filters, separators and/or condensers. In case of doubt consult LEYBOLD.



2.3 Connection to exhaust side

No isolation or restricting devices should be installed in the exhaust line of the pump.

If an exhaust line is installed, it must at least have the same diameter as the exhaust flange. It should be installed in a manner so that no condensate can enter the pump (siphon, slope).

The maximum exhaust pressure must neither exceed 1.15 bar absolute (0.15 bar relative), nor fall under atmosphere pressure minus 15 mbar corresponding pressure regulating devices to be installed by the user.

Pump exhaust to be connected if oil mist or process gases are to be avoided in the pump area.

Warning



2.4 Oil filling

The necessary oil is supplied in a can beside the pump. To fill in the oil, unscrew the oil fill plug and fill in until the oil level reaches the MAX-mark beside the oil sight glass.

Operating of the pump without oil or operating with incorrect direction of rotation can destroy the pump or lead to oil back streaming.

Warning



Installation

Warning



2.5 Electrical connection

Never expose part of the body to the vacuum. There is a danger of injury. Never operate the pump with an open and thus accessible inlet.

Vacuum connections as well as oil filling and oil draining openings must not be opened during operation of the pump.

The electrical installation may only be conducted by a specialist. IEC regulations have to be followed as well as local or country regulations.

Voltage and frequency mentioned on the motor nameplate must agree with the supply voltage.

The drive motor must be protected against over loads according to IEC 60204-1 and IEC 61010-1.

To check the direction of rotation of pumps with three-phase motor, flick the ON/OFF switch for a short time at atmospheric pressure. If the direction of rotation is not identical with the one indicated by the arrow sticking on the motor hood, then inverse any two of the electrical phases in the terminal box. Looking at the motor fan cover, the direction of rotation has to be counter-clockwise.

The single phase and three phase pumps have cable glands on the motor. The user has to wire the mains cable in accordance with the indications given on the motor name plate and in its connection box.

It is important to have a good grounding connection.

Lay the cable to avoid tripping risk.

Warning



2.6 Operating advices

The intake line of the pump must never be connected to a device with over atmospheric pressure. Size of the exhaust line so that no pressure higher than 1.15 bar abs. (0.15 bar rel.) can occur.

When removing condensable vapours, a gas ballast valve must be used.

The vacuum pump must be run for 30 minutes before operating with condensable vapours with the inlet connection closed, in order to reach the operating temperature of about 75°C. Only up from this operating temperature, condensable vapours can be pumped. After use, the pump has to be left running for an additional 30 minutes with the inlet connection closed, to clear the oil of condensates.

Use ear protection in case of operation at high inlet pressures.

Clean eventual oil on the floor.

2.7 Shutdown

The inlet flange of the SOGEVAC® pumps contains an anti-suck back valve. It closes the inlet flange when the pump is voluntarily or accidentally shut down, thus maintaining the vacuum in the connected system and preventing oil from being sucked back into the system.

Except the indications in chapter 2.6 (operating advices) there are no particular precautions for the shutdown of the pump. If the pump must be stopped for a longer period, see chapter 1.6.2.

The anti-suck back valve operates reliably only if kept in good and clean condition. It is not a safety valve.

Maintenance

3 Maintenance

Disconnect the power before disassembling the pump. Make absolutely sure that the pump cannot be accidentally started and wait 2 minutes.

Warning



If the Pump has pumped harmful substances, ascertain the nature of the hazard and takes adequate safety measures. Observe all safety regulations.

Warning



Service at Leybold

If you send a pump to Leybold indicate whether the pump is free of substances damaging to health or whether it is contaminated. If it is contaminated also indicate the nature of hazard. For this you must use the form we have prepared and which will be provided upon request.

A copy of this form, "Declaration of Contamination of Vacuum Instruments and Components" is reproduced at the end of the Operating Instructions.

Please attach this form to the pump, or enclose it with it.

This Declaration is required to meet the law and to protect our personnel.

Leybold will return any pump received without a "Declaration of Contamination" to the sender's address.

The pump must be packaged in such a way that it will not be damaged during shipping, and so that no harmful substances can escape from the package.

If you open a pump at your own works also observe a potential contamination.

Warning



When disposing of used oil, please observe the relevant environmental regulations.

Warning



Due to the design concept of the SOGEVAC, maintenance is normally kept to a minimum. The work required is described in the sections below.

All work on the pump must be carried out by suitably trained personnel. Maintenance or repairs done incorrectly affect the life performance of the pump and may cause problems when filing warranty claims.

Maintenance

3.1 Maintenance Schedule

The intervals stated in the maintenance schedule are approximate values for normal pump operation. Unfavorable ambient conditions and/or aggressive media may significantly reduce the maintenance intervals.

Maintenance job	Frequency	Section
Oil level checking	Daily	3.2
1st oil change	After 150 h of operation	3.3
Subsequent oil changes	Every 500 to 2000 h (depending on application) of operation or 6 months	3.3
Exhaust filter replacement	If oil mist at ex-haust or annually	3.4
Gas ballast valve	Monthly checking	3.5
Inlet flange sifter cleaning	6 months	3.6
Anti-suck back valve checking	6 months	3.7
Fan cover cleaning	6 months	3.8
Electrical connection checking (only by a specialist)	6 months	

In order to simplify the maintenance work we recommend to combine several jobs.

Caution

Warning



Never use discarded seals. Always assemble using new seals.

The pump is hot and some surfaces could reach a temperature higher than 80°C (176°F).

There is a risk of burn by touching.

Warning



Depending on the process involved, dangerous substances and oil may escape from the pump. Take the necessary safety precautions!

Note

Respect the instructions concerning environment protection when discarding used oil or exhaust filters!

3.2 Oil level

The oil level should be checked at least once a day. If the oil level is below the "MAX" mark, oil has to be added until the level reaches the mark. If the oil level is below the "MIN" mark, stop the pump and check it (see chapter 4).

3.3 Oil changing

Oil must be changed after the first 150 operating hours. Further oil changes, depending on operating conditions (products, vapours, ambient temperature...) must be done every 500 to 2000 operating hours or at least every 6 months.

If there is considerable pollution, it could be necessary to change the oil more frequently. Oil changing must be done with a switched off and still warm pump.

Open the oil drain plug and let run out the used oil into an appropriate container. Refasten the oil drain plug when oil runs slower, start up the pump briefly (5 sec. max) and switch off immediately. Reopen the oil drain plug and drain the rest of the oil.

Before refastening the oil drain plug, inspect the O-ring and if necessary replace it. Open the oil fill plug and pour in clean oil ; refasten the oil fill plug. The pump has to be rinsed out if there is considerable pollution. Therefore pour in clean oil up to the low edge of the oil level glass, let the pump run briefly (for a few minutes) then drain the oil again.

3.4 Exhaust filters replacement

Oil mist escaping from the exhaust during operation indicates that the filter is probably choked up. Increased motor current could also be the result of a dirty exhaust filter. Open the exhaust hood, take out the filter and replace it.

Also check the gasket of the exhaust flange and change it if necessary.

3.5 Gas ballast cleaning

If the filter of the gas ballast is dirty, the gas ballast is no longer operative. The filter has to be replaced (see spare parts list).

3.6 Inlet flange sifter cleaning

To clean the inlet flange sifter, disconnect the inlet flange and clean the sifter with blast air or an appropriate solvent.

3.7 Anti-suck back valve checking

The anti-suck back valve should be checked at the same time as the inlet flange screen and if dirty, be cleaned with an appropriate solvent. Also check, if there is no damage on the sealing part of the valve.

3.8 Fan cover cleaning

Dirt blockage of the fan cover may lead to over heating of the motor and the pump. Put off the cover and clean it with blast air. Before starting the pump again, be sure that the cover has been reassembled.

3.9 Checking the oil recovery system

When replacing the exhaust filter, check the cleanliness and the proper operation of the float valve.

After having disassembled the exhaust flange, unscrew the oil recovery screw and push the float valve by using its metallic part inside the oil casing, clean the nozzle and check that the float itself oscillates free around its axle and that the valve is tight.

Clean the float chamber of the oil casing. Reassemble in the reverse sequence.

Problem analysis

4. Problem analysis Troubleshooting Guide

Fault	Possible cause	Remedy	Reference section*
Pump does not start	Pump is connected incorrectly	Connect the pump correctly	2.5
	Motor protection switch incorrectly set.	Set motor protection switch properly	2.5
	Operating voltage does not match motor	Replace the motor	-
	Motor is malfunctioning	Replace the motor	-
	Oil temperature is below 12°C (54°F)	Heat the pump and pump oil or use different oil	2.1
	Oil is too viscous	Use appropriate oil grade	3.3
	Exhaust filter / exhaust line is clogged	Replace the filter or clean the exhaust line	3.4
Pump does not reach ultimate pressure	External leak	Repair the pump	-
	Float valve does not close	Repair the valve	3.9
	Anti-suckback valve is malfunctioning	Repair the valve	3.7
	Inadequate lubrication due to : - unsuitable or contaminated oil - clogged oil lines	Change the oil (degas it, if necessary). Clean the oil casing	3.3 -
	Vacuum lines are dirty	Clean vacuum lines	-
	Pump is too small	Check the process data ; replace the pump, if necessary	-
Pumping speed is too low	Dirt trap in the intake port is clogged	Clean the dirt trap. Precaution : install a dust filter in intake line	3.6
	Exhaust filter is clogged	Install new filter elements	3.4
	Connecting lines are too narrow or too long.	Use adequately wide and short connecting lines.	2.2
After switching off pump under vacuum, pressure in system rises too fast	System has a leak.	Check the system	-
	Anti-suckback is malfunctioning	Repair the valve	3.7
Pump gets too hot	Cooling air supply is obstructed	Set pump up correctly	1.4
	Cooler is dirty	Clean the cooler	-
	Ambient temperature is too high	Set pump up correctly max 40□	-
	Process gas is too hot	Change the process	-
	Oil level is too low	Add oil to reach the correct oil level	3.3
	Oil is unsuitable	Change the oil	3.3
	Oil cycle is obstructed	Clean or repair the oil lines	-
Exhaust filter / exhaust line is obstructed	Replace the exhaust filter, clean the exhaust line	3.4	
Oil in intake line or in vacuum vessel	Oil comes from the vacuum system	Check the vacuum system	-
	Anti-suckback valve is obstructed	Clean or repair the valve	3.7
	Sealing surfaces or anti-suckback valve are damaged or dirty	Clean or repair the intake port and valve	3.7
	Oil level is too high	Drain the excess oil	3.3
Pump's oil consumption too high, oil mist at exhaust	Exhaust filters are clogged or damaged.	Replace the filters.	3.4
	Nozzle of float valve is clogged.	Check the valve, clean the nozzle.	3.9
	Oil level is too high.	Drain the excess oil.	3.3
Oil is turbid	Condensation	Degas the oil or change the oil and clean the pump	2.6
		Precaution : open the gas ballast valve or insert a condensate trap.	-
		Clean the gas ballast intake filter	3.5
Pump is excessively noisy	Oil level is very low (oil is no longer visible)	Add oil	3.3

* Reference section: This column refers to the section in the Operating Instructions that contains the applicable repair information.
N.B.: Never mount used seals. Always mount new seals.

EU Declaration of Conformity

(Translation of original Declaration of Conformity)

The manufacturer: Leybold Equipment (Tianjin) Co., Ltd.
No.8 Shuangchenxi Rd.
Beichen Economic Development Area (BEDA)
Tianjin, 300400, PR China

herewith declares that the products specified and listed below which we have placed on the market, comply with the applicable EU Council Directives. This declaration becomes invalid if modifications are made to the product without agreement of Leybold.

Product designation: SOGEVAC
Type: SV10B, SV16B, SV25B, SV40B, SV65B, SV100B, SV200, SV300B, SV630B(F), SV750B(F), SV10FP, SV16FP, SV25FP, SV45FP, SV70FP, SV105FP, SV200FP and SV300FP, and their variants, excepted pumps delivered without motor

The products complies to the following European Council Directives:

Machinery Directive (2006/42/EC)

The safety objectives of the Low Voltage Directive 2014/35/EU were complied with in accordance with Appendix 1 No. 1.5.1 of Machinery Directive 2006/42/EC.

Electromagnetic Compatibility (2014/30/EU)

RoHS Directive (2011/65/EU) & (2015/863/EU)

The following harmonized standards have been applied:

EN 1012-2:1996+A1:2009	Compressors and vacuum pumps — Safety requirements — Part 2: Vacuum pumps
EN 60204-1:2006/A1:2009	Safety of machinery — Electrical equipment of machines — Part 1: General requirements
EN 61000-6-2:2005/AC:2005	Electromagnetic compatibility (EMC) - Part 6-2: Generic standards - Immunity for industrial environments
EN 61000-6-4:2007/A1:2011	Electromagnetic compatibility (EMC) - Part 6-4: Generic standards - Emission standard for industrial environments

Documentation officer: Herbert Etges
Leybold GmbH, Bonner Str. 498, D-50968 Köln
T: +49(0)221 347 0
F: +49(0)221 347 1250
documentation@leybold.com

Cologne, April 26, 2017



ppa. Andries Desiron
VP Engineering
Industrial Vacuum Division

Cologne, April 26, 2017

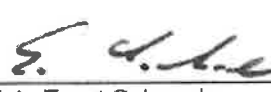

i.A. Ernst Schnacke
Head of Quality Assurance Methods
& Technical Standards

Declaration of Contamination of Compressors, Vacuum Pumps and Components

The repair and / or servicing of compressors, vacuum pumps and components will be carried out only if a correctly completed declaration has been submitted. Non-completion will result in delay. The manufacturer can refuse to accept any equipment without a declaration.

A separate declaration has to be completed for each single component.

This declaration may be completed and signed only by authorized and qualified staff.

Customer/Dep./Institute : _____ Address : _____ _____ Person to contact: _____ Phone : _____ Fax: _____ End user: _____	Reason for return: <input checked="" type="checkbox"/> applicable please mark Repair: <input type="checkbox"/> chargeable <input type="checkbox"/> warranty Exchange: <input type="checkbox"/> chargeable <input type="checkbox"/> warranty <input type="checkbox"/> Exchange already arranged / received Return only: <input type="checkbox"/> rent <input type="checkbox"/> loan <input type="checkbox"/> for credit Calibration: <input type="checkbox"/> DKD <input type="checkbox"/> Factory-calibr. <input type="checkbox"/> Quality test certificate DIN 55350-18-4.2.1																									
A. Description of the Leybold product: _____ Failure description: _____ Material description : _____ Catalog number: _____ Additional parts: _____ Serial number: _____ Application-Tool: _____ Type of oil (ForeVacuum-Pumps) : _____ Application- Process: _____																										
B. Condition of the equipment <table style="width: 100%; border-collapse: collapse;"> <thead> <tr> <th style="width: 60%;"></th> <th style="width: 10%; text-align: center;">No¹⁾</th> <th style="width: 10%; text-align: center;">Yes</th> <th style="width: 10%; text-align: center;">No</th> <th style="width: 10%;"></th> </tr> </thead> <tbody> <tr> <td>1. Has the equipment been used</td> <td style="text-align: center;"><input type="checkbox"/></td> <td style="text-align: center;"><input type="checkbox"/></td> <td style="text-align: center;"><input type="checkbox"/></td> <td></td> </tr> <tr> <td>2. Drained (Product/service fluid)</td> <td style="text-align: center;"><input type="checkbox"/></td> <td style="text-align: center;"><input type="checkbox"/></td> <td style="text-align: center;"><input type="checkbox"/></td> <td></td> </tr> <tr> <td>3. All openings sealed airtight</td> <td style="text-align: center;"><input type="checkbox"/></td> <td style="text-align: center;"><input type="checkbox"/></td> <td style="text-align: center;"><input type="checkbox"/></td> <td></td> </tr> <tr> <td>4. Purged</td> <td style="text-align: center;"><input type="checkbox"/></td> <td style="text-align: center;"><input type="checkbox"/></td> <td style="text-align: center;"><input type="checkbox"/></td> <td></td> </tr> </tbody> </table> <p style="margin-left: 20px;">If yes, which cleaning agent _____ and which method of cleaning _____</p> <p>¹⁾ If answered with "No", go to D. ←</p>			No ¹⁾	Yes	No		1. Has the equipment been used	<input type="checkbox"/>	<input type="checkbox"/>	<input type="checkbox"/>		2. Drained (Product/service fluid)	<input type="checkbox"/>	<input type="checkbox"/>	<input type="checkbox"/>		3. All openings sealed airtight	<input type="checkbox"/>	<input type="checkbox"/>	<input type="checkbox"/>		4. Purged	<input type="checkbox"/>	<input type="checkbox"/>	<input type="checkbox"/>	
	No ¹⁾	Yes	No																							
1. Has the equipment been used	<input type="checkbox"/>	<input type="checkbox"/>	<input type="checkbox"/>																							
2. Drained (Product/service fluid)	<input type="checkbox"/>	<input type="checkbox"/>	<input type="checkbox"/>																							
3. All openings sealed airtight	<input type="checkbox"/>	<input type="checkbox"/>	<input type="checkbox"/>																							
4. Purged	<input type="checkbox"/>	<input type="checkbox"/>	<input type="checkbox"/>																							
C. Description of processed substances (Please fill in absolutely) 1. What substances have come into contact with the equipment? Trade name and / or chemical term of service fluids and substances processed, properties of the substances According to safety data sheet (e.g. toxic, inflammable, corrosive, radioactive) <table border="1" style="width: 100%; border-collapse: collapse;"> <thead> <tr> <th style="width: 5%;"></th> <th style="width: 35%;">Tradename:</th> <th style="width: 60%;">Chemical name:</th> </tr> </thead> <tbody> <tr><td>X</td><td></td><td></td></tr> <tr><td>a)</td><td></td><td></td></tr> <tr><td>b)</td><td></td><td></td></tr> <tr><td>c)</td><td></td><td></td></tr> <tr><td>d)</td><td></td><td></td></tr> </tbody> </table>			Tradename:	Chemical name:	X			a)			b)			c)			d)									
	Tradename:	Chemical name:																								
X																										
a)																										
b)																										
c)																										
d)																										
2. Are these substances harmful? <input type="checkbox"/> No <input type="checkbox"/> Yes 3. Dangerous decomposition products when heated? <input type="checkbox"/> No <input type="checkbox"/> Yes If yes, which? _____																										
<p>²⁾ Components contaminated by microbiological, explosive or radioactive products/substances will not be accepted without written evidence of decontamination.</p>																										

D. Legally binding declaration

I / we hereby declare that the information supplied on this form is accurate and sufficient to judge any contamination level.

Name of authorized person (block letters) : _____ _____ Date _____	signature of authorized person _____ _____	<div style="border: 1px dashed black; width: 100%; height: 100%; display: flex; align-items: center; justify-content: center;"> </div>
--	---	--

Spare parts

Spare parts

To guarantee safe operation of the Leybold pump, only original spare parts and accessories shall be used. When ordering spare parts and accessories, always state pump type and serial number. You can find part numbers in the spare parts list.

Consumables and main spare parts kits for SOGEVAC® pumps are usually available on stock at Leybold's service centers. The list of these parts is given here after and in the spare parts table where the contents of each kits is detailed.

- Exhaust demister.
- Oil LVO120 (Special oils please refer to the specific notice of the pump or contact Leybold).
- Service kit.
- Set of seals.
- Repair kit.

We recommend to use these kits which have been defined to allow an optimal maintenance or repair. Individual spare parts may need longer delivery time.

Repairs requiring the replacement of the stator or the rear endplate should be made by the Leybold Service.

Spare parts

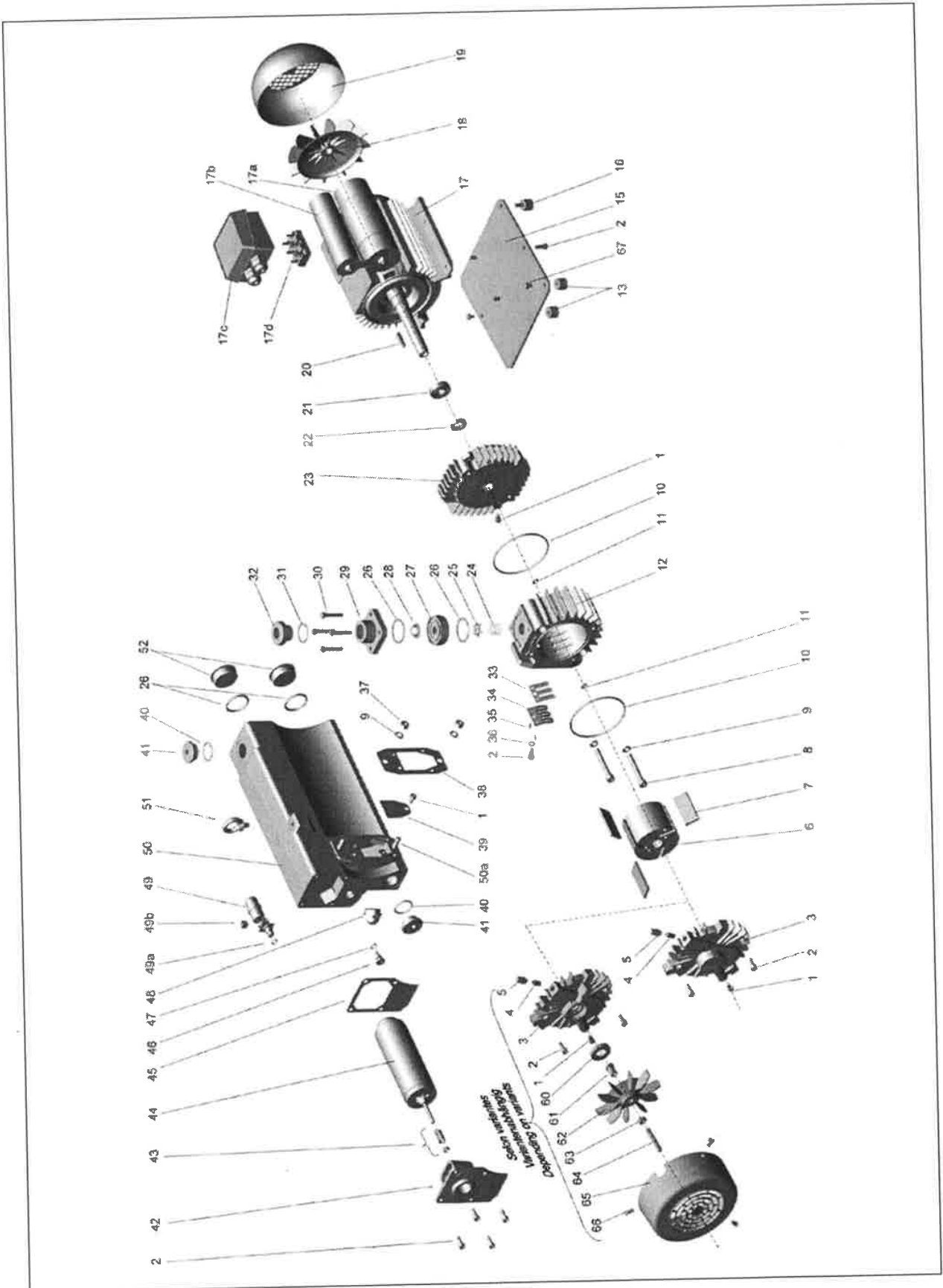

Spare parts

Spare parts List

Pos.	Qty	Specification	Dimensions (mm), material	Ref. no.	Notes
1	3	Screw	CHC M6 x 10 Q8.8		
2	10	Screw	CHC M6 x 16 Q8.8		
3	1	End plate with GB		971422940	Incl. 4,5
3	1	End plate without GB		971422950	
3	1	Fan end plate with GB		71421710	Incl. 4,5
3	1	Fan end plate W/O GB		971446770	
4	1	GB screw kit		71418070	
5	1	GB silencer		71418060	
6	1	Rotor		71416310	
7	3	Vane set of 3		71416290	
8	2	Screw	CHC M8 x 60 Q8.8		
9	4	Washer	W8		
10	2	O-ring	93	FKM 71237720	
11	2	O-ring	6,02 X 2,62	FKM 71237600	
12	1	Pump cylinder			Consult Leybold Service
13	2	Rubber mount	D20x15 M6	71418020	
15	1	Supporting plate		71416240	
16	1	Rubber mount	D20x15 M6	71414030	
17	1	Motor 1PH	0,9/1,1KW 230V 50/60Hz		Incl. 17a,c,d,18,19,20,21,22,23 Consult Leybold Service
17a	1	Capacitor	40µF	971423050	
17c	1	Terminal box		971422800	
17d	1	Terminal board		971423090	
17	1	Motor 1ph	0,9/1,1KW 100V 50/60Hz		Incl. 17a,b,c,d,18,19,20,21,22,23 Consult Leybold Service
17a	1	Capacitor	110µF	971423060	
17b	1	Capacitor	110µF	971423060	
17c	1	Terminal box		971423130	
17d	1	Terminal board		971422830	
17	1	Motor 1PH	1,1KW 115V 60Hz		Incl. 17a,b,c,d, 18,19,20,21,22,23 Consult Leybold Service
17a	1	Capacitor	110µF	971423060	
17b	1	Capacitor	60µF	971423070	
17c	1	Terminal box		971423130	
17d	1	Terminal board		971422830	
		Set of seals		FKM 71419490	
		Repair kit		971423100	
		Service kit		971423450	

Spare parts

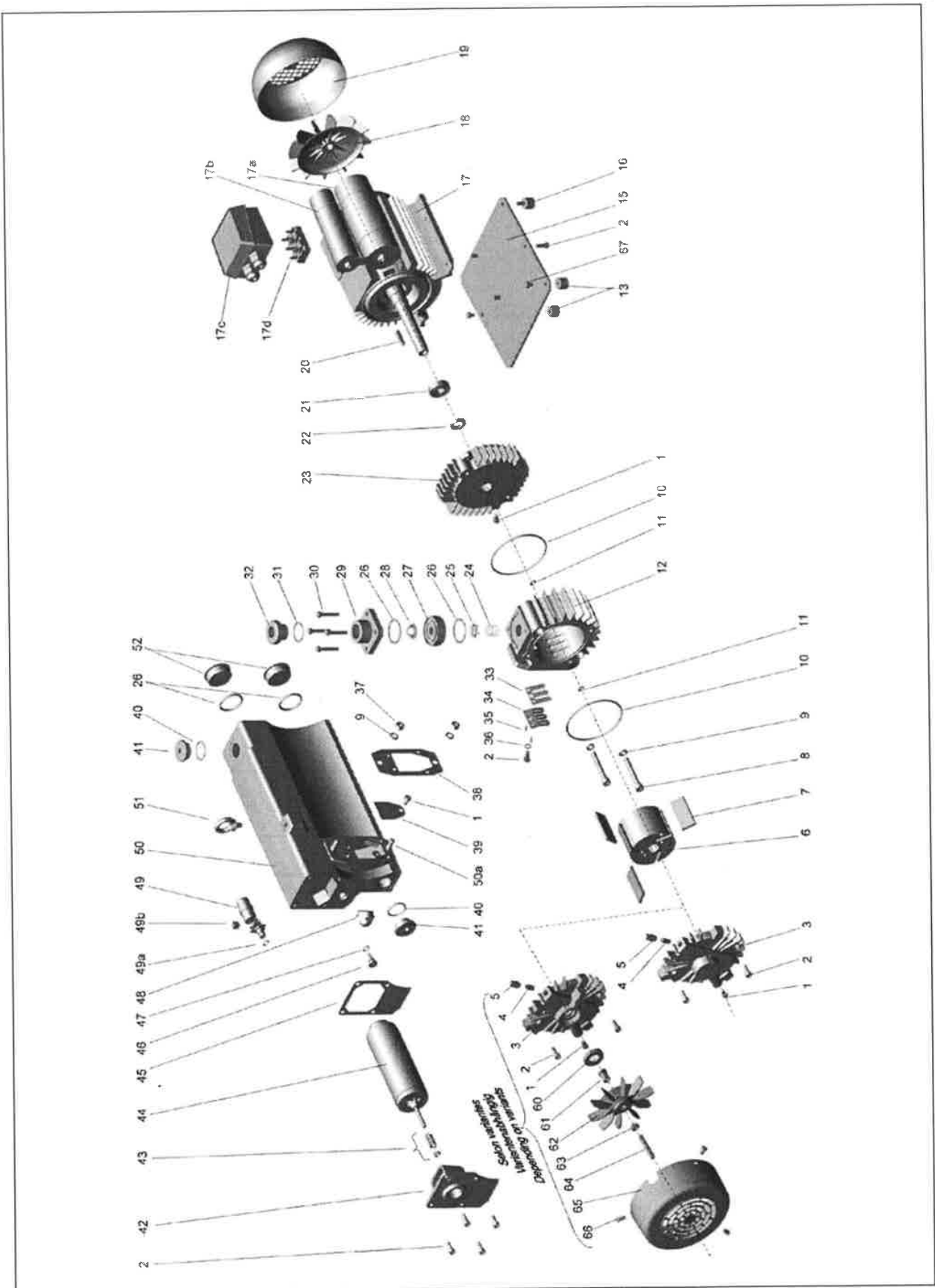

Spare parts

Spare parts List

Pos.	Qty	Specification	Dimensions (mm), material	Ref. no.	Notes			
17	1	Motor 3PH	0,9/1,1KW 230/400V 50Hz IE3 200-240/346-415V 50Hz 200-277/346-480V 60Hz		Incl.17C,d,18,19,20,21,22,23 Consult Leybold Service			
17c	1	Terminal box			Consult Leybold Service			
17d	1	Terminal board			Consult Leybold Service			
18	1	Fan			Consult Leybold Service			
19	1	Fan cover			Consult Leybold Service			
20	1	Key	6X30	71416300				
21	1	Ball bearing			Consult Leybold Service			
22	1	Radial shaft seal		FKM	Consult Leybold Service		●	
23	1	End bearing plate			Consult Leybold Service			
24	1	Inlet spring		71415640				
25	1	Anti suckback valve		71042990			●	
26	4	O-ring	34.52	FKM 71419340			●	
27	1	Inlet adapter		71413110				
28	1	Dirt trap		71413440				
29	1	Intake flange	G 3/4	71416170				
29	1	Intake flange	NPT 3/4	71418080				
30	4	Screw	CHC M6 x 35 Q8.8					
31	1	O-ring	28	FKM 71217590			●	
32	1	Reduction + o-ring	G 3/4-G 1/2	95124	Incl.31			
32	1	Reduction	NPT 3/4- NPT 1/2	71422140				●
33	1	Valve plate		71418570				●
34	1	Valve stop		71418580				●
35	2	Centering pin	D3.5X10					
36	1	Washer	WZ6					
37	2	Nut	HM8 Q6					
38	1	Flat gasket		71419730			●	
39	1	Grid		71416180				
40	2	O-ring	27 X 2.5	FKM 71217580			●	●
41	2	Plug , slotted	HC G 3/4	71256380	Incl.40			
42a	1	Exhaust flange	G 3/4	71416220				
42b	1	Exhaust flange	NPT 3/4	71418090				
43	1	Spring unit		71420370				●
44	1	Exhaust filter		71416340				●
45	1	Flat gasket		971423480			●	●
46	1	Oil return screw		71420720	Incl.47			●
47	1	O-ring	8X2	FKM 71217650			●	
48	1	Oil level glass	3/4	71219480			●	
49	1	Float compl.		71417210	Incl.49a,b			
49a	1	O-ring	8X2	FKM 71217650			●	
49b	1	Oil return valve seal		71212500			●	
50	1	Oil casing		71421730	Incl.50a			
50a	2	Locking screw	M8-25/15J=12 Q6.8					
51	1	Lifting lug	M8	71402970				
52	2	Plug + o-ring	G 1 1/4	71420140	Incl.26			
60	1	Radial shaft seal	DN18x35x7	71419180			●	
61	1	Fan hub		71422030				
62	1	Fan		71419190				
63	1	Nut	M8					
64	1	Screw	HC M8x50					
65	1	Cover		71420250	Incl.66			
66	3	Screw	HC M6x12					
67	2	Screw	CHC M6x8 Q8.8					
		Set of seals		FKM 71419490				●
		Repair kit		971423100				●
		Service kit		971423450				●

Sales and Service

Germany

Leybold GmbH
Sales, Service, Support Center (3SC)
Bonner Strasse 498
D-50968 Cologne
T: +49-(0)221-347 1234
F: +49-(0)221-347 31234
sales@leybold.com
www.leybold.com

Leybold GmbH
Sales Area North
Branch Office Berlin
Industriestrasse 10b
D-12099 Berlin
T: +49-(0)30-435 609 0
F: +49-(0)30-435 609 10
sales.bn@leybold.com

Leybold GmbH
Sales Office South
Branch Office Munich
Karl-Hammerschmidt-Strasse 34
D-85609 Aschheim-Dornach
T: +49-(0)89-357 33 9-10
F: +49-(0)89-357 33 9-33
sales.mn@leybold.com
service.mn@leybold.com

Leybold Dresden GmbH
Service Competence Center
Zur Wetterwarte 50, Haus 304
D-01109 Dresden
Service:
T: +49-(0)351-88 55 00
F: +49-(0)351-88 55 041
info.dr@leybold.com

Europe

Belgium

Leybold Nederland B.V.
Belgisch bijkantoor
Leuvensesteenweg 542-9A
B-1930 Zaventem
Sales:
T: +32-2-711 00 83
F: +32-2-720 83 38
sales.zv@leybold.com
Service:
T: +32-2-711 00 82
F: +32-2-720 83 38
service.zv@leybold.com

France

Leybold France S.A.S.
Parc du Technopolis, Bâtiment Beta
3, Avenue du Canada
F-91940 Les Ulis cedex
Sales and Service:
T: +33-1-69 82 48 00
F: +33-1-69 07 57 38
info.ctb@leybold.com
sales.ctb@leybold.com

Leybold France S.A.S.
Valence Factory
640, Rue A. Bergès
B.P. 107
F-26501 Bourg-lès-Valence Cedex
T: +33-4-75 82 33 00
F: +33-4-75 82 92 69
marketing.vc@leybold.com

Great Britain

Leybold UK LTD.
Unit 9
Silverglade Business Park
Leatherhead Road
Chessington
Surrey (London)
KT9 2QL
Sales:
T: +44-13-7273 7300
F: +44-13-7273 7301
sales.ln@leybold.com
Service:
T: +44-13-7273 7320
F: +44-13-7273 7303
service.ln@leybold.com

Italy

Leybold Italia S.r.l.
Via Trasimeno 8
I-20128 Mailand
Sales:
T: +39-02-27 22 31
F: +39-02-27 20 96 41
sales.mi@leybold.com
Service:
T: +39-02-27 22 31
F: +39-02-27 22 32 17
service.mi@leybold.com

Netherlands

Leybold Nederland B.V.
Floridadreef 102
NL-3565 AM Utrecht
Sales and Service:
T: +31-(30) 242 63 30
F: +31-(30) 242 63 31
sales.ut@leybold.com
service.ut@leybold.com

Switzerland

Leybold Schweiz AG, Pfäffikon
Hinterbergstrasse 56
CH-6312 Steinhausen
Warehouse and shipping address:
Riedthofstrasse 214
CH-8105 Regensdorf
Sales:
T: +41-44-308 40 50
F: +41-44-302 43 73
sales.zh@leybold.com
Service:
T: +41-44-308 40 62
F: +41-44-308 40 60
service.zh@leybold.com

Spain

Leybold Spain, S.A.
C/. Huelva, 7
E-08940 Cornellà de Llobregat
(Barcelona)
Sales:
T: +34-93-666 43 11
F: +34-93-666 43 70
sales.ba@leybold.com
Service:
T: +34-93-666 46 11
F: +34-93-685 43 70
service.ba@leybold.com

America

USA

Leybold USA Inc.
5700 Mellon Road
USA-Export, PA 15632
T: +1-724-327-5700
F: +1-724-325-3577
info.ex@leybold.com
Sales:
T: +1-724-327-5700
F: +1-724-333-1217
Service:
T: +1-724-327-5700
F: +1-724-325-3577

Brazil

Leybold do Brasil
Rod. Vice-Prefeito Hermenegildo Tonolli,
No. 4413 - 6B
Distrito Industrial
Jundiá - SP
CEP 13.213-086
Sales and Service:
T: +55 11 3395 3180
F: +55 11 99467 5934
sales.ju@leybold.com
service.ju@leybold.com

Asia

P. R. China

Leybold (Tianjin)
International Trade Co. Ltd.
Beichen Economic
Development Area (BEDA),
No. 8 Western Shuangchen Road
Tianjin 300400
China
Sales and Service:
T: +86-400 038 8989
F: +86-800 818 0033
F: +86-22-2697 4061
F: +86-22-2697 2017
sales.tj@leybold.com
service.tj@leybold.com

India

Leybold India Pvt Ltd.
No. 82(P), 4th Phase
K.I.A.D.B. Plot
Bommasandra Industrial Area
Bangalore - 560 099
Indien
Sales and Service:
T: +91-80-2783 9925
F: +91-80-2783 9926
sales.bgl@leybold.com
service.bgl@leybold.com

Japan

Leybold Japan Co., Ltd.
Headquarter
Shin-Yokohama A.K.Bldg., 4th Floor
3-23-3, Shin-Yokohama
Kohoku-ku, Yokohama-shi
Kanagawa 222-0033
Japan
Sales:
T: +81-45-471-3330
F: +81-45-471-3323
sales.yh@leybold.com

Leybold Japan Co., Ltd.
Tsukuba Technical Service Center
1959, Kami-yokoba
Tsukuba-shi, Ibaraki-shi 305-0854
Japan
Service:
T: +81-29 839 5480
F: +81-29 839 5485
service.iik@leybold.com

Malaysia

Leybold Malaysia
Leybold Singapore Pte Ltd.
No. 1 Jalan Hi-Tech 2/6
Kulim Hi-Tech Park
Kulim, Kedah Darul
Aman 09000
Malaysia
Sales and Service:
T: +604 4020 222
F: +604 4020 221
sales.ku@leybold.com
service.ku@leybold.com

South Korea

Leybold Korea Ltd.
3F, Jellzone 2 Tower
Jeongja-dong 159-4
Bundang-gu Sungnam-si
Gyeonggi-do
Bundang 463-384, Korea
Sales:
T: +82-31 785 1367
F: +82-31 785 1359
sales.bd@leybold.com
Service:
623-7, Upsung-Dong
Cheonan-Si
Chungcheongnam-Do
Korea 330-290
T: +82-41 589 3035
F: +82-41 588 0166
service.cn@leybold.com

Singapore

Leybold Singapore Pte Ltd.
42 Loyang Drive
Loyang Industrial Estate
Singapore 508962
Singapore
Sales and Service:
T: +65-6303 7030
F: +65-6773 0039
sales.sg@leybold.com
service.sg@leybold.com

Taiwan

Leybold Taiwan Ltd.
No 416-1, Sec. 3
Chungshin Rd., Chutung
Hsinchu County 310
Taiwan, R.O.C.
Sales and Service:
T: +886-3-500 1688
F: +886-3-583 3999
sales.hc@leybold.com
service.hc@leybold.com

www.leybold.com